

17 TS << TS

DC-5V

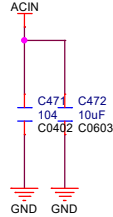

RTC

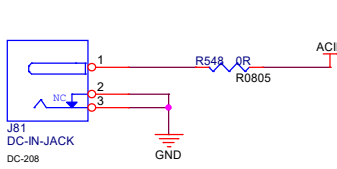
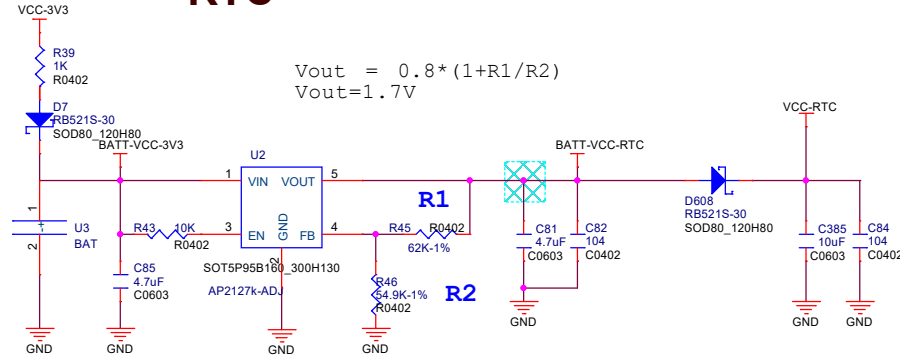

$$V_{out} = 0.8 * (1 + R1/R2)$$

$$V_{out} = 1.7V$$

SINK FROM VINT WHEN PMIC POWER IS PRESENT

BAT

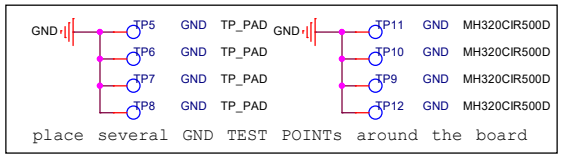
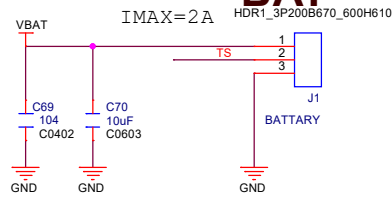

Linden Tech. Ltd.		
Design Name: Linden V536		
Size: A3	Page Name: POWER	Rev:
Date: Monday, February 03, 2020	Sheet: 1	of 13

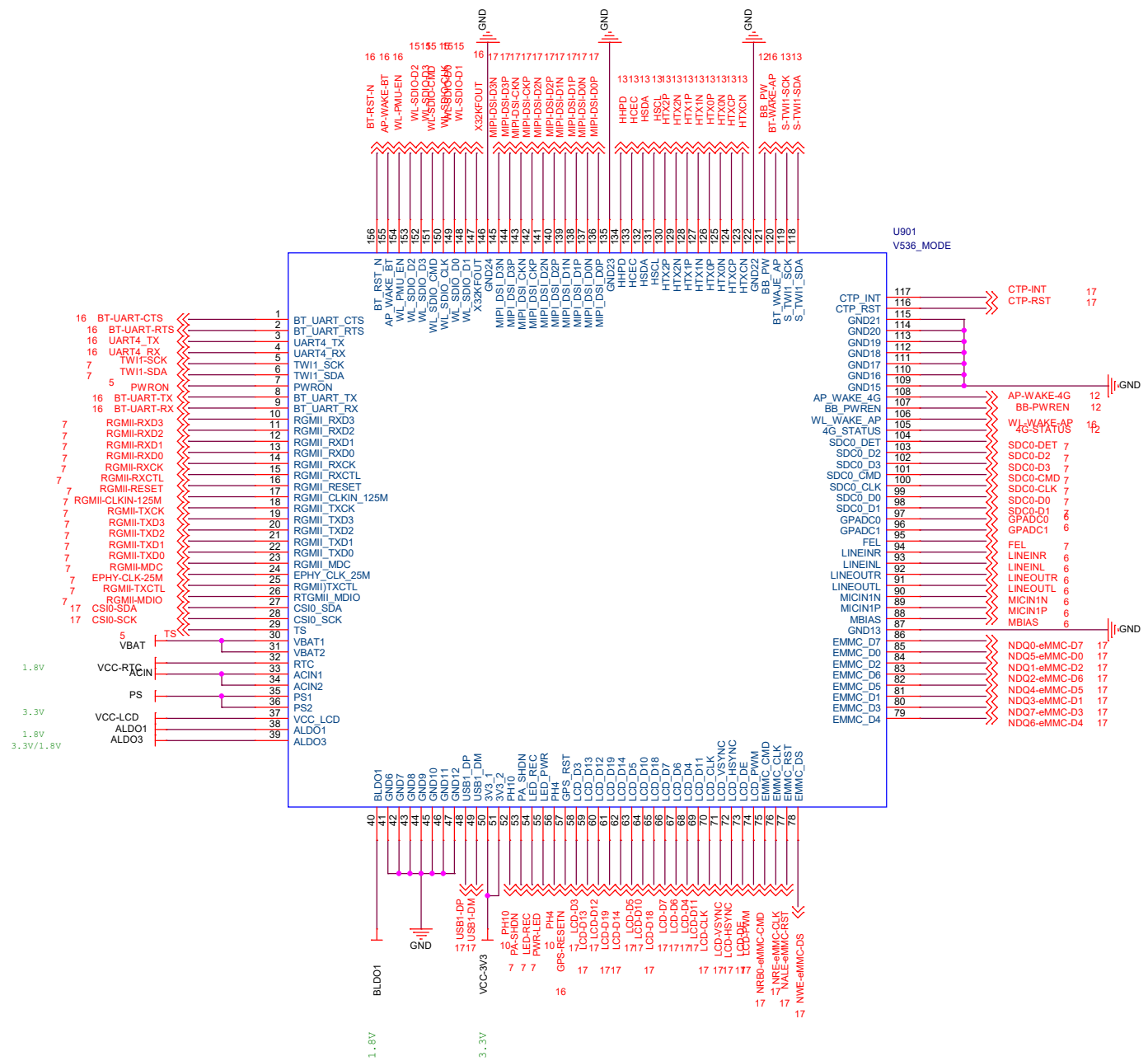

5

4

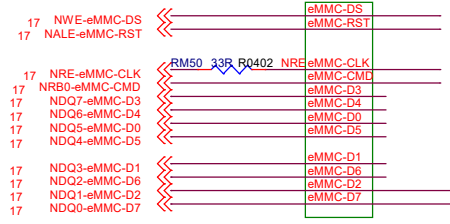

Flash

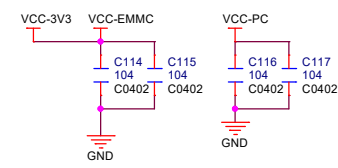
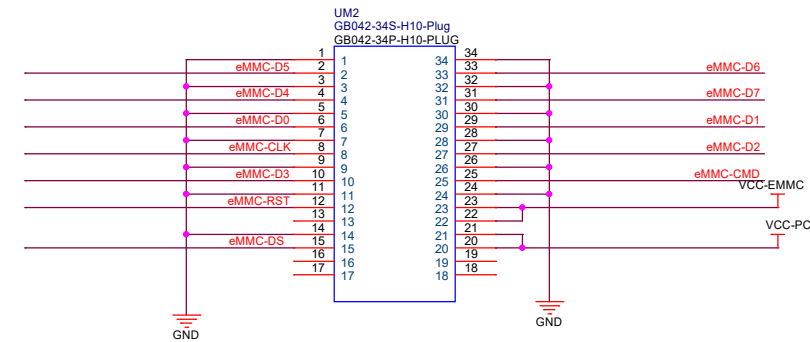

CARD

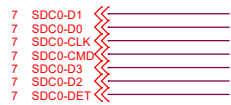

VCC-CARD



NOTE:
VCC-CARD: fixed to 3.3V
SDC0-DET SDC0-CMD: use internal pull-up

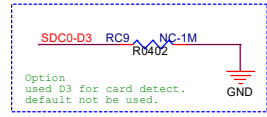
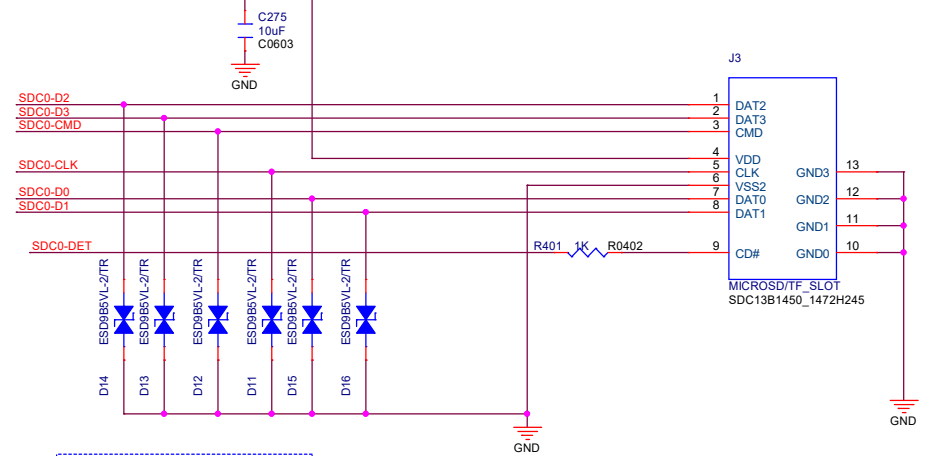

USB

USB HUB

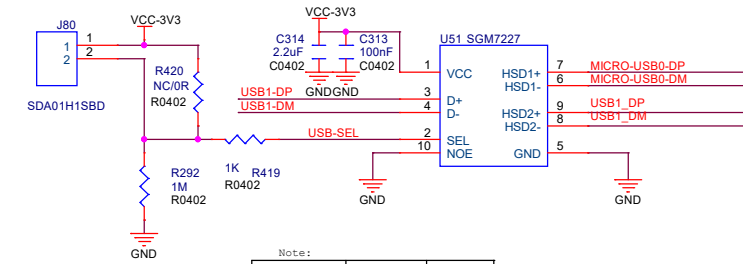
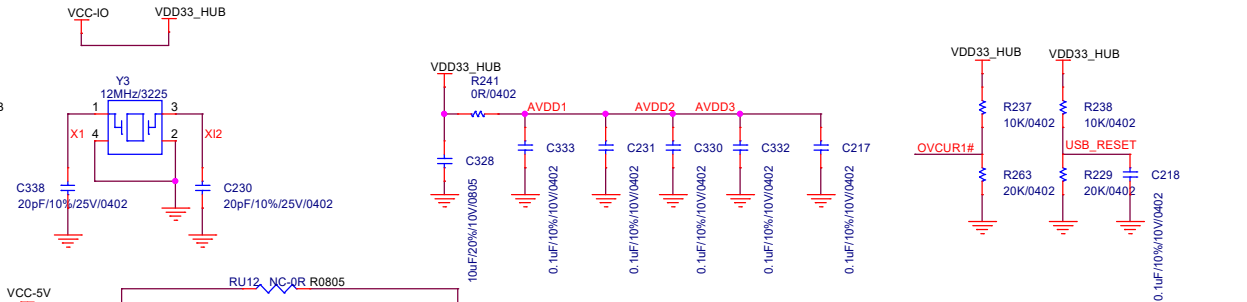
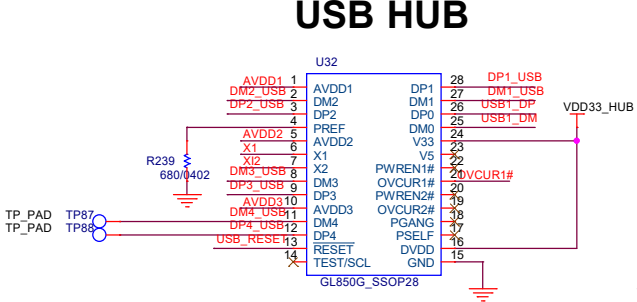
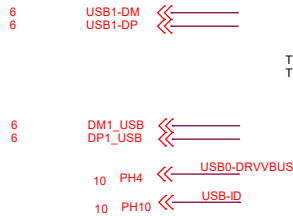

Note:

USB-SEL	MICRO-USB	4G-USB
L	ON	OFF
H	OFF	ON

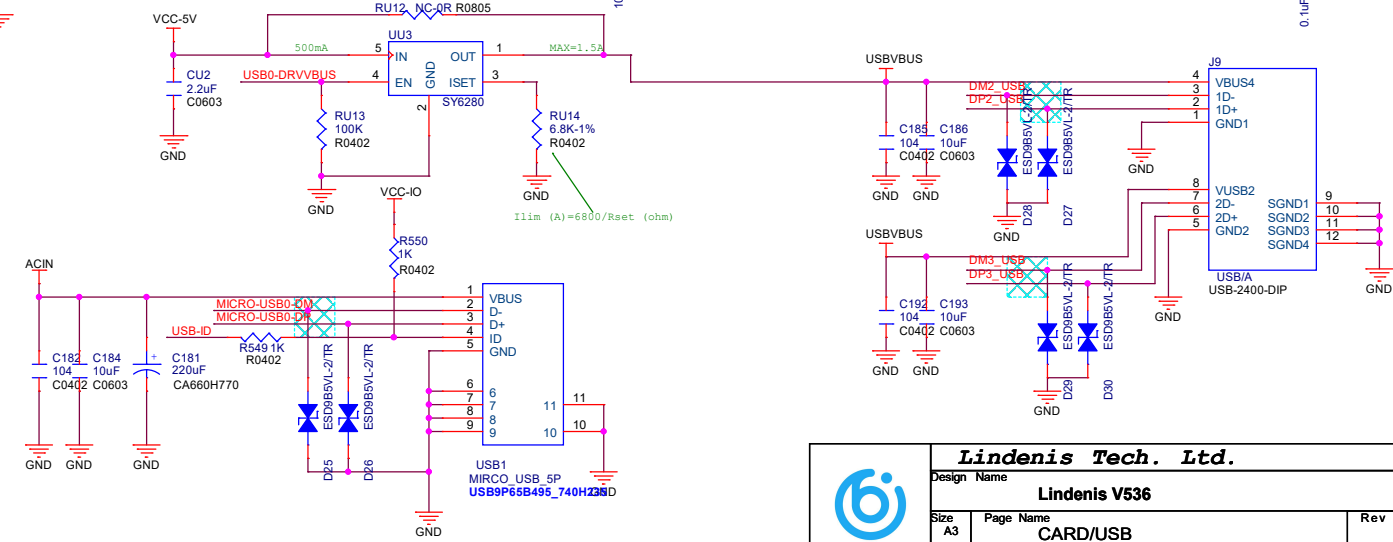

Linden Tech. Ltd.
Design Name
Linden V536
Size A3 Page Name **CARD/USB** Rev
Date: Monday, February 03, 2020 Sheet 4 of 13

AUDIO

5

MIC(Electret)

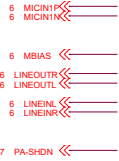
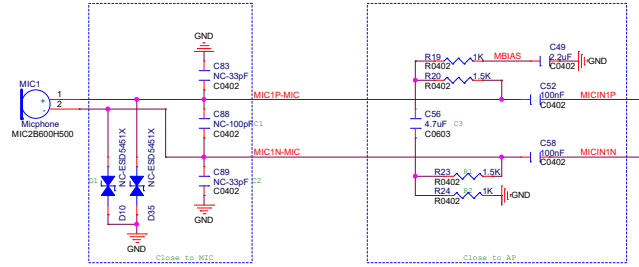

4

3

COMPONENT	Differential	Single-ended
R1, R2, C1, C3, D1	ISE	NC
C2	330P	OR

I2S CONN

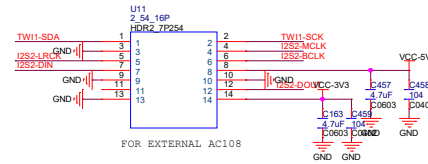

I2S2_MCLK	R0402	NC_OR	R525	I2S2_MCLK
I2S2_BCLK	R0402	NC_OR	R526	I2S2_BCLK
I2S2_LRCK	R0402	NC_OR	R527	I2S2_LRCK
I2S2_DOUT	R0402	NC_OR	R528	I2S2_DIN
I2S2_DIN	R0402	NC_OR	R529	I2S2_DOUT



SPEAKER

2

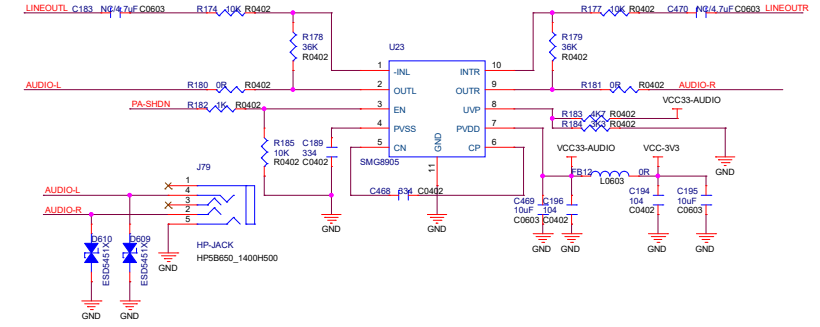

LINE IN

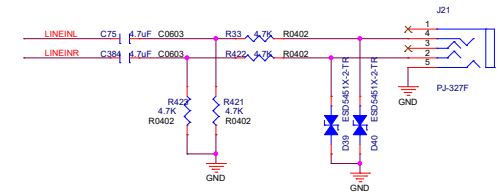

1

HDMI

6
6
6
6
6
6
6
6
5
5
6
5

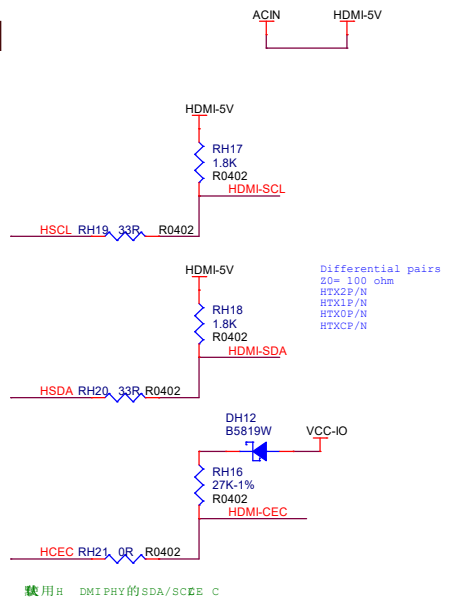

載用H DMIPHY的SDA/SCE C

Differential pairs Z0= 100 ohm

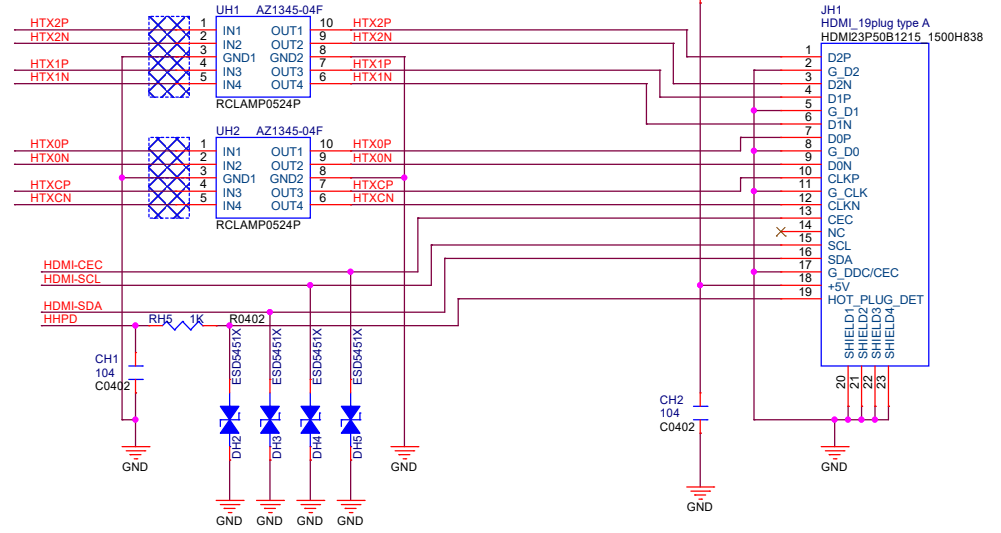

DVP

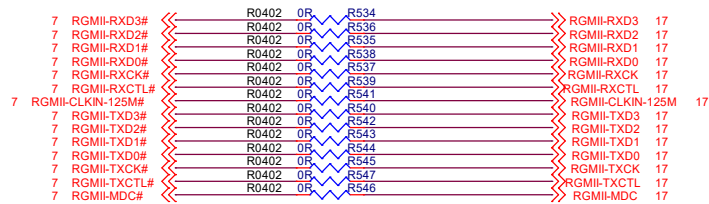
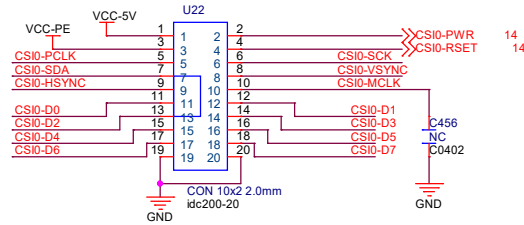
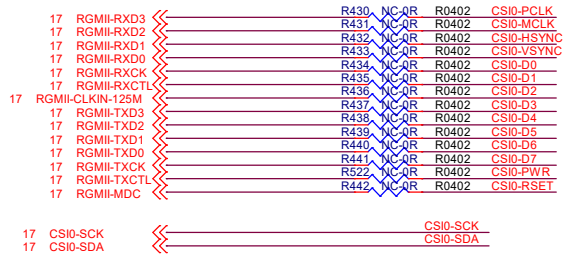

KEY

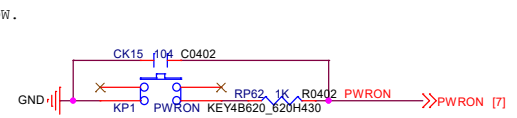
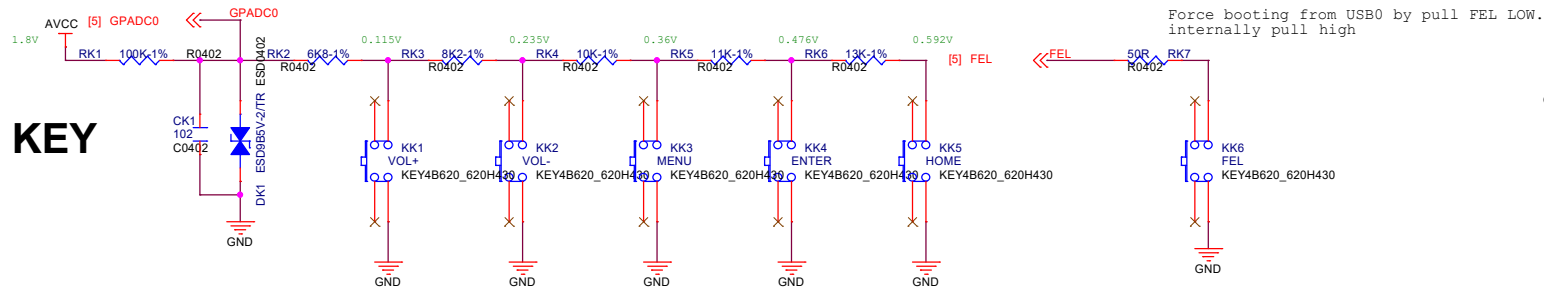

G-SENSOR

12 S-TWI1-SCK
12 S-TWI1-SDA

7 PWR-LED
7 LED-REC

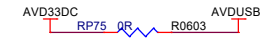
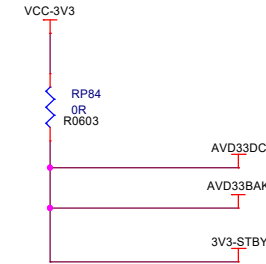

7 GPS-RESETN
7 UART4_TX
7 UART4_RX

GPS-RESETN
GPS-RXD0
GPS-TXD0

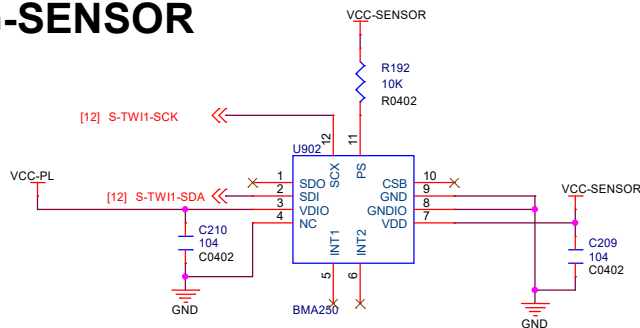

LED

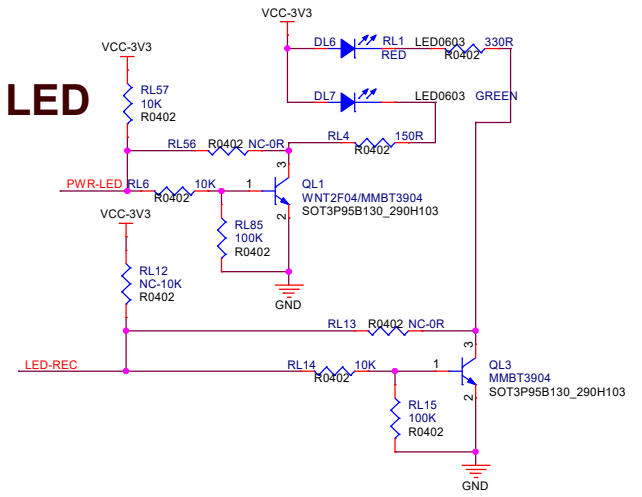

GPS

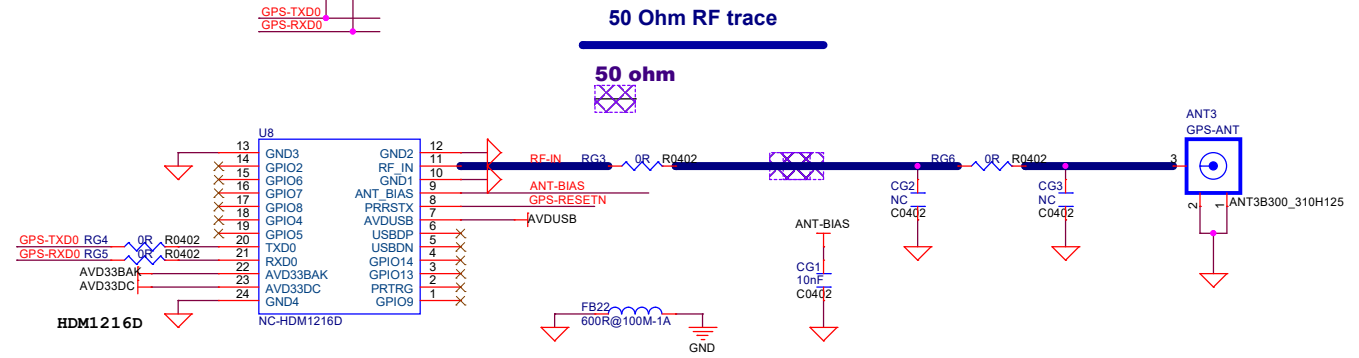
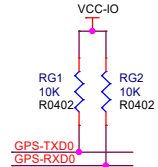

WIFI

APXXX

VCC33-WIFI

VCC18-WIFI

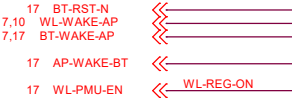
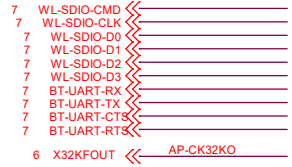

VCC18-WIFI VCC-WIFHO

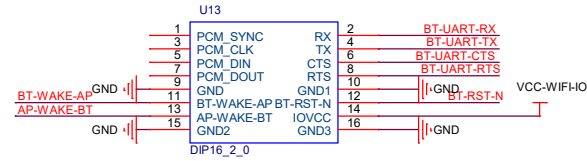
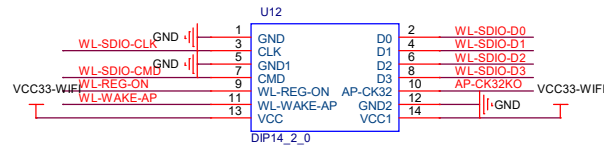
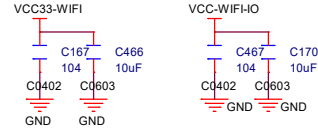

SIM7600

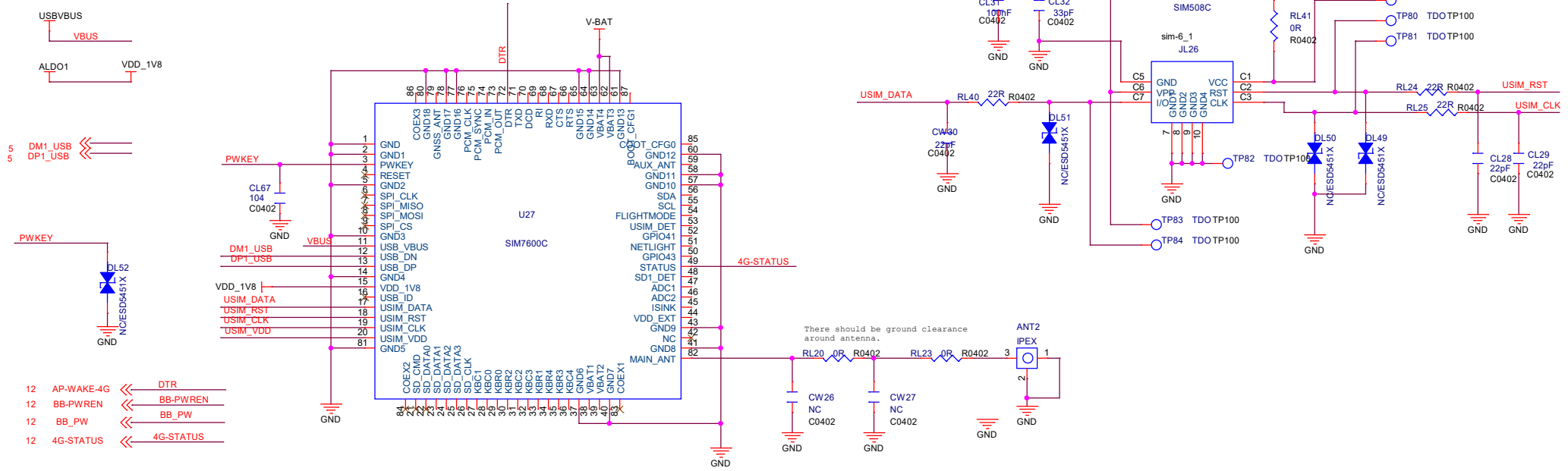

- 12 AP-WAKE-4G << DTR
- 12 BB-PWREN << BB-PWREN
- 12 BB_PW << BB_PW
- 12 4G-STATUS << 4G-STATUS

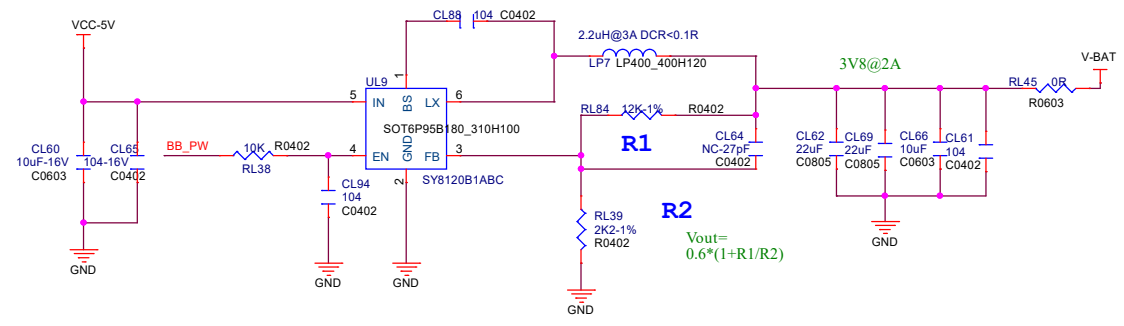
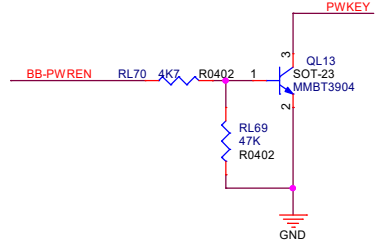
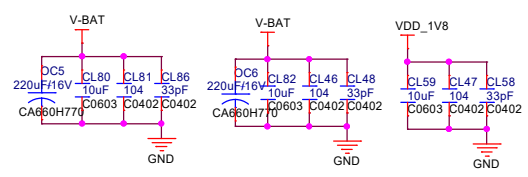

Lindeniz Tech. Ltd.		
Design Name		
Lindeniz Airdoc V5		
Size	Page Name	Rev
A3	SIM7600CE	
Date:	Monday, February 03, 2020	Sheet 11 of 13

ETHERNET

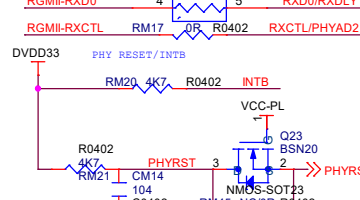
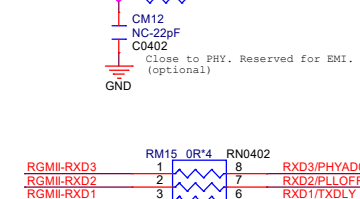
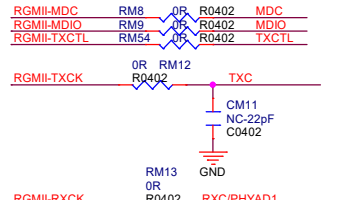
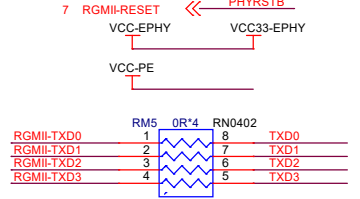
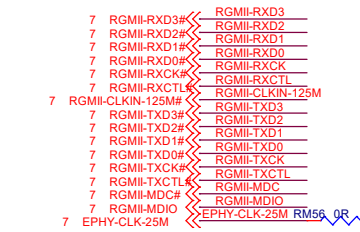

NOTE: IN RGMII MODE ,TXCK IS INOUT Pin

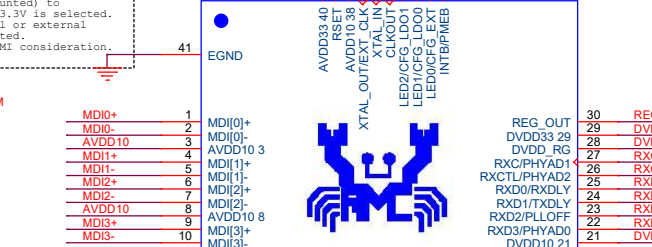
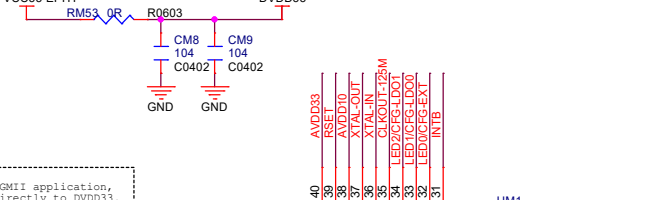
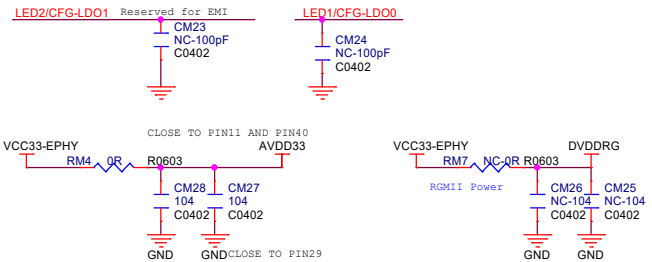

RGMII Power Source	CFG_EXT	CFG_LD0[1:0]
External 3.3V (default)	1'b1	2'b00
External 2.5V	1'b1	2'b01
External 1.8V	1'b1	2'b10
External 1.5V	1'b1	2'b11
Internal 2.5V	1'b0	2'b01
Internal 1.8V	1'b0	2'b10
Internal 1.5V	1'b0	2'b11

PHY Address	PHYAD[2:0]
0 (default)	3'b000
1	3'b001

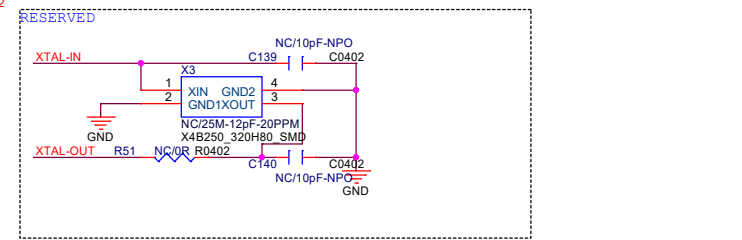
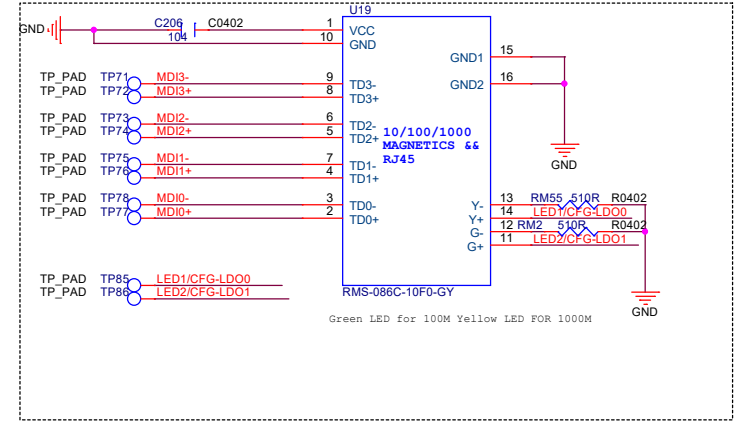

Lindenis Tech. Ltd.

Design Name **Lindenis V536**

Size A3 Page Name **ETHERNET** Rev

Date: **Monday, February 03, 2020** Sheet **12** of **13**

CON

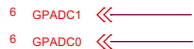

GPIO

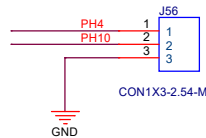

TWI

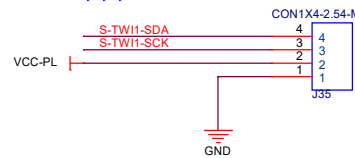
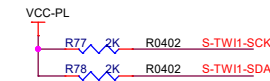
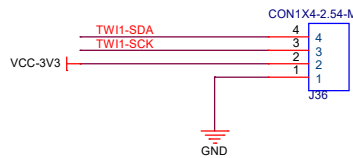
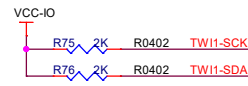

UART

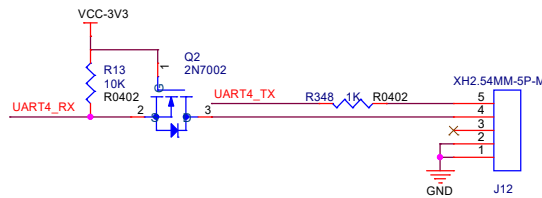

ADC

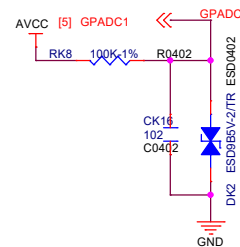
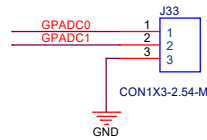

POWER

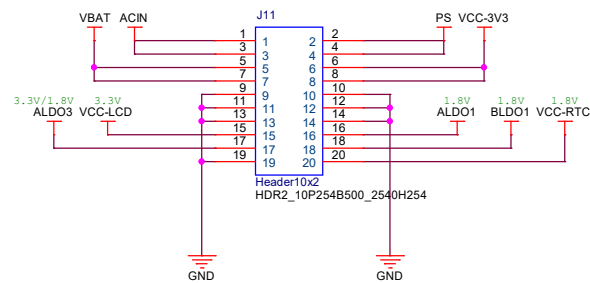

Linden Tech. Ltd.		
Design Name		
Linden V536		
Size	Page Name	Rev
A3	CON	
Date: Monday, February 03, 2020		
Sheet		13 of 13